

Light oil burners

Single stage operation

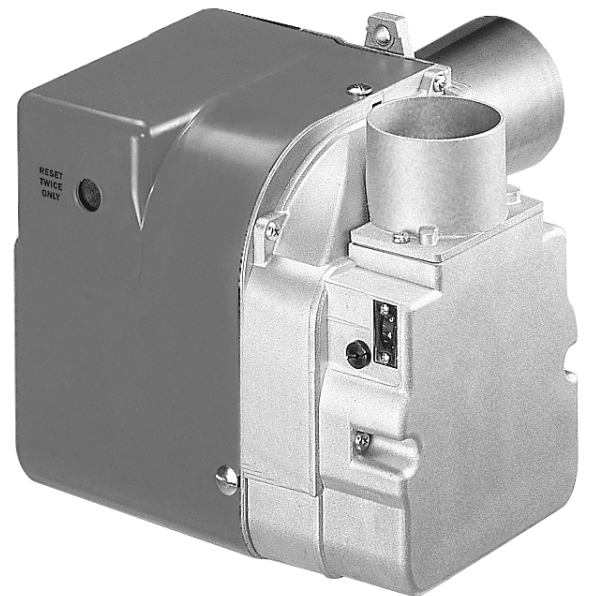

RDB

CODE	MODEL
20045452	RDB2.2R T1 BF FCX22
20045453	RDB2.2R T3 BF FCX30

1	Information and general instructions	3
1.1	Information about the instruction manual	3
1.1.1	Introduction	3
1.1.2	General dangers	3
1.1.3	Safety precautions	3
1.1.4	Danger: live components	3
1.2	Guarantee and responsibility	4
1.2.1	Owner's responsibility	4
2	Safety and prevention	5
2.1	Introduction	5
2.2	Personnel training	5
3	Technical description of the burner	6
3.1	Technical data	6
3.2	Burner models designation	6
3.3	Accessories (optional)	6
3.4	Burner description	7
3.5	Packaging - weight - Approximate measurements	7
3.6	Standard equipment	7
3.7	Burner dimensions	8
3.8	Firing rate	9
4	Installation	10
4.1	Installation precautions	10
4.2	Notes on safety for the installation	11
4.3	Handling	11
4.4	Preliminary checks	11
4.5	Working position	11
4.6	Burner assembly	12
4.6.1	CF - Chimney Vent Application	12
4.6.2	BF - Direct Vent Application	12
4.7	A typical layout for RDB burner intake air	13
4.8	Boiler fixing	14
4.9	Hydraulic systems	15
4.9.1	General warnings	15
4.9.2	Oil line connections	15
4.9.3	Priming pump	16
4.10	Electrical wiring	17
4.10.1	Control box	17
4.11	Electrical wiring	18
5	Burner operation	19
5.1	Combustion adjustment	19
5.2	Nozzles	19
5.2.1	Nozzles recommended	19
5.3	Pump pressure	19
5.4	Burner adjustment table	20
5.5	Air damper adjustment	21
5.6	Electrodes setting	22
5.7	Fuel heating	22
5.8	Burner start-up cycle	22

6	Maintenance	23
6.1	Notes on safety for the maintenance	23
6.2	Maintenance programme	23
6.2.1	Maintenance frequency	23
6.2.2	Checking and cleaning	23
7	Faults / Solutions	24
8	Spare parts	25
8.1	Exploded spare parts	25
8.2	Spare parts list	26

1

Information and general instructions

1.1 Information about the instruction manual



READ THESE INSTRUCTIONS AND SAVE FOR REFERENCE

1.1.1 Introduction

The instruction manual supplied with the burner:

- is an integral and essential part of the product and must not be separated from it; it must therefore be kept carefully for any necessary consultation and must accompany the burner even if it is transferred to another owner or user, or to another system. If the manual is lost or damaged, another copy must be requested from the Technical Assistance Service of the area;
- is designed for use by qualified personnel;
- offers important indications and instructions relating to the installation safety, start-up, use and maintenance of the burner.

Symbols used in the manual

In some parts of the manual you will see triangular DANGER signs. Pay great attention to these, as they indicate a situation of potential danger.

1.1.2 General dangers

The **dangers** can be of **3 levels**, as indicated below.



Maximum danger level!
This symbol indicates operations which, if not carried out correctly, **cause** serious injury, death or long-term health risks.



This symbol indicates operations which, if not carried out correctly, **may cause** serious injury, death or long-term health risks.



This symbol indicates operations which, if not carried out correctly, **may cause** damage to the machine and/or injury to people.

1.1.3 Safety precautions

Good safety practices must be used when working on burner equipment. The potential energy in the electrical supply, fuel and related equipment must be handled with extreme care to prevent equipment failures, injuries and potential death.



If you smell gas, open window, extinguish any open flames, stay away from electrical switches, evacuate the building and immediately call the gas company.

If this equipment is not installed, operated, operated and maintained in accordance with the manufacturers instructions, this product could expose you to substances in fuel or from fuel combustion which can cause death or serious illness.



Improper servicing of this equipment may create a potential hazard to equipment and operators.
Servicing must be done by a fully trained and qualified personnel.

1.1.4 Danger: live components



This symbol indicates operations which, if not carried out correctly, lead to electric shocks with lethal consequences.

Other symbols



ENVIRONMENTAL PROTECTION

This symbol gives indications for the use of the machine with respect for the environment.

- This symbol indicates a list.

Abbreviations used

Ch.	Chapter
Fig.	Figure
Pag.	Page
Sec.	Section
Tab.	Table

Delivery of the system and the instruction manual

When the system is delivered, it is important that:

- The instruction manual is supplied to the user by the system manufacturer, with the recommendation to keep it in the room where the heat generator is to be installed.
- The instruction manual shows:
 - the serial number of the burner;

.....

- the address and telephone number of the nearest Assistance Centre;

.....

.....

.....

- The system supplier carefully informs the user about:
 - the use of the system,
 - any further tests that may be necessary before the system is started up,
 - maintenance and the need to have the system checked at least once a year by the manufacturer or another specialised technician.

To ensure a periodic check, the manufacturer recommends the drawing up of a Maintenance Contract.

1.2 Guarantee and responsibility

The manufacturer guarantees its new products from the installation date, in accordance with the regulations in force and/or the sales contract. At the moment of the first start-up, check that the burner is integral and complete.



Failure to observe the information given in this manual, operating negligence, incorrect installation and the carrying out of non authorised modifications will result in the annulment by the manufacturer of the guarantee that it supplies with the burner.

In particular, the rights to the guarantee and the responsibility will no longer be valid, in the event of damage to things or injury to people, if such damage/injury was due to any of the following causes:

- incorrect installation, start-up, use and maintenance of the burner;
- improper, incorrect or unreasonable use of the burner;
- intervention of unqualified personnel;
- carrying out of non authorised modifications on the equipment;
- use of the burner with safety devices that are faulty, incorrectly applied and/or not working;
- installation of untested supplementary components on the burner;
- powering of the burner with unsuitable fuels;
- faults in the fuel power supply system;
- use of the burner even following an error and/or an irregularity;
- repairs and/or overhauls incorrectly carried out;
- modification of the combustion chamber with inserts that prevent the regular development of the flame, as structurally established;
- insufficient and inappropriate surveillance and care of those burner components most subject to wear and tear;
- use of non-original components, including spare parts, kits, accessories and optionals;
- force majeure.

The manufacturer furthermore declines any and every responsibility for the failure to observe the contents of this manual.

1.2.1 Owner's responsibility

Please pay attention to the Safety Warnings contained within this instruction manual. Keep this manual for your records and provide it to your qualified service agency for use in professionally setting up and maintaining your burner.

Your burner will provide years of efficient operation if it is professionally installed and maintained by a qualified service technician. If at any time the burner does not appear to be operating properly, immediately contact your qualified service agency for consultation.

We recommend annual inspection/service of your gas heating system by a qualified service agency.

Failure to follow these instructions, misuse, or incorrect adjustment of the burner could lead to equipment malfunction and result in asphyxiation, explosion or fire.



If you smell gas:

- Do not touch any electrical items.
- Open all windows.
- Close all gas supply valves.
- Contact your local gas authority immediately.
- Do not store flammable or hazardous materials in the vicinity of fuel burning appliances.
- Improper installation, adjustment, alteration, service or maintenance can cause property damage, personal injury or death.
- Refer to this manual for instructional or additional information.
- Consult a certified installer, service representative or the gas supplier for further assistance.
- Burner shall be installed in accordance with manufacturers requirements as outlined in this manual, local codes and authorities having jurisdiction.

2

Safety and prevention

2.1 Introduction

The burners have been designed and built in compliance with current regulations and directives, applying the known technical rules of safety and envisaging all the potential danger situations.

It is necessary, however, to bear in mind that the imprudent and clumsy use of the equipment may lead to situations of death risk for the user or third parties, as well as the damaging of the burner or other items. Inattention, thoughtlessness and excessive confidence often cause accidents; the same applies to tiredness and sleepiness.

It is a good idea to remember the following:

- The burner must only be used as expressly described. Any other use should be considered improper and therefore dangerous. In particular: it can be applied to boilers operating with water, steam, diathermic oil, and to other users expressly named by the

manufacturer;

the type and pressure of the fuel, the voltage and frequency of the electrical power supply, the minimum and maximum deliveries for which the burner has been regulated, the pressurisation of the combustion chamber, the dimensions of the combustion chamber and the room temperature must all be within the values indicated in the instruction manual.

- Modification of the burner to alter its performance and destinations is not allowed.
- The burner must be used in exemplary technical safety conditions. Any disturbances that could compromise safety must be quickly eliminated.
- Opening or tampering with the burner components is not allowed, apart from the parts requiring maintenance.
- Only those parts envisaged by the manufacturer can be replaced.

2.2 Personnel training

The user is the person, body or company that has acquired the machine and intends to use it for the specific purpose. He is responsible for the machine and for the training of the people working around it.

The user:

- Undertakes to entrust the machine exclusively to suitably trained and qualified personnel.
- Must take all the measures necessary to prevent unauthorised people gaining access to the machine.
- Undertakes to inform his personnel in a suitable way about the application and observance of the safety instructions. With that aim, he undertakes to ensure that everyone knows the use and safety instructions for his own duties.
- Must inform the manufacturer if faults or malfunctioning of the accident prevention systems are noticed, along with any presumed danger situation.

- Personnel must always use the personal protective equipment envisaged by legislation and follow the indications given in this manual.
- Personnel must follow all the danger and caution indications shown on the machine.
- Personnel must not carry out, on their own initiative, operations or interventions that are not within their province.
- Personnel are obliged to inform their superiors of every problem or dangerous situation that may arise.
- The assembly of parts of other makes, or any modifications, can alter the characteristics of the machine and hence compromise operating safety. The manufacturer therefore declines any and all responsibility for any damage that may be caused by the use of non-original parts.

3

Technical description of the burner

3.1 Technical data

Model			RDB 2.2R T1 BF FCX22	RDB 2.2R T3 BF FCX30
Output ⁽¹⁾		Btu/hr ⁽²⁾	70.000 - 98.000	81.200 - 154.000
Delivery ⁽¹⁾		GPH	0.50 - 0.70	0.58 - 1.10
Fuel			# 1 and # 2 Fuel Oil	
Operation			Single stage	
Nozzle	number		1	
Ambient temperature		°F	32 - 104	
Combustion air temperature		°F max	140	
Main power supply (+/- 10%)		V/Ph/Hz	Single phase, ~ 60Hz 120V ± 10%	
Electric motors		rpm	3450	
Motor		V	120	
		W - HP	90 - 0.12	
		A	2.2	
		µF	12.5	
Ignition transformer			Secondary 8 kV - 16 mA	
Pump	Delivery (at 174 PSI)	GPH	15	
	Pressure range	PSI	116 - 217	
Electrical power consumption		W max	150 - 0.2	

Tab. A

(1) Reference conditions: ambient temperature 68 °F (20°C) - Barometric pressure 394" WC - Altitude 329 ft.

(2) Equivalent Btu values based on 1 USGPH = 140,000 Btu/hr.
BF (Direct Vent Application) or CF (Chimney Vent Application)

* # 1 ASTM D 396 & # 2 Fuel Oil

3.2 Burner models designation

Model	Code	Voltage	Flame safeguard
RDB 2.2R T1 BF FCX22	20045452	120/1/60	Burner mounted
RDB 2.2R T3 BF FCX30	20045453	120/1/60	Burner mounted

3.3 Accessories (optional)

- CF conventional flue conversion kit
- Light oil filter

NOTE:

The installer is responsible for the supply and installation of any required safety device(s) not indicated in this manual.

3.4 Burner description

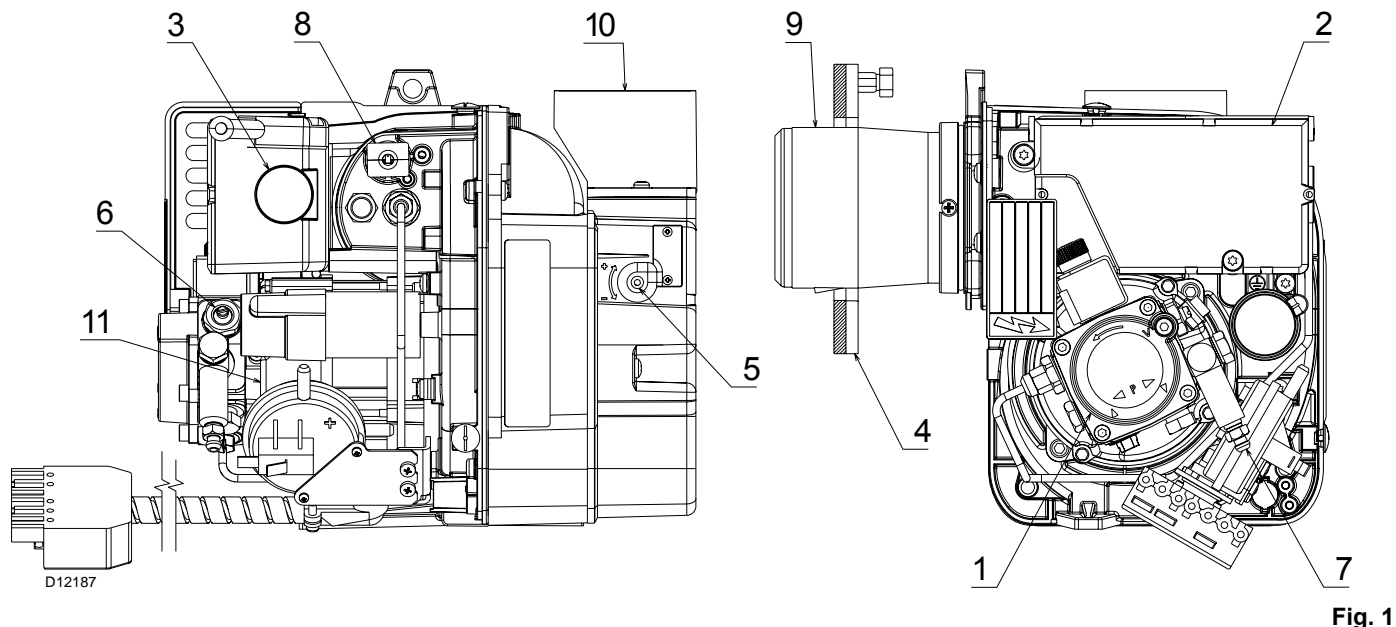

- | | |
|-----------------------------------|----------------------|
| 1 Oil pump | 7 Bleeder connection |
| 2 Control box | 8 Flame detector |
| 3 Reset button with lock-out lamp | 9 Combustion head |
| 4 Flange with insulating gasket | 10 Air intake (CF) |
| 5 Air damper adjustment screw | 11 Motor |
| 6 Pump pressure adjustment screw | |

3.5 Packaging - weight - Approximate measurements

The burners are skid mounted. Outer dimensions of packaging are indicated in Tab. B.

The weight of the burner complete with packaging is indicated in Tab. B.

inch	A	B	C	lbs
RDB 2.2R T1 BF FCX22	15 ³⁵ / ₆₄ "	11 ³⁹ / ₆₄ "	12 ¹ / ₆₄ "	24.3
RDB 2.2R T3 BF FCX30	15 ³⁵ / ₆₄ "	11 ³⁹ / ₆₄ "	12 ¹ / ₆₄ "	24.3

Tab. B

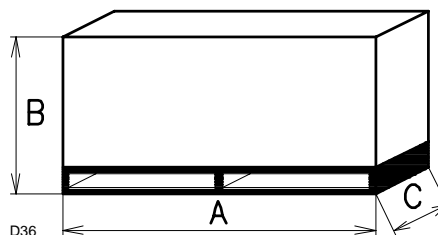

Fig. 2

3.6 Standard equipment

- 1 - Burner head gasket
- 1 - Flange with insulating gasket
- 1 - Screw of by-pass pump
- 1 - Screw and nuts for flange
- 1 - 4 pin plug
- 1 - Hexagonal key
- 1 - Nipple 3/8 - 1/4
- 4 - Screws for flange to be fixed to boiler
- 1 - Nipple 3/8 - 3/8
- 2 - Pipe connectors
- 2 - Female adaptors 1/4 NPT

3.7 Burner dimensions

The maximum dimensions of the burner is given in Fig. 3.

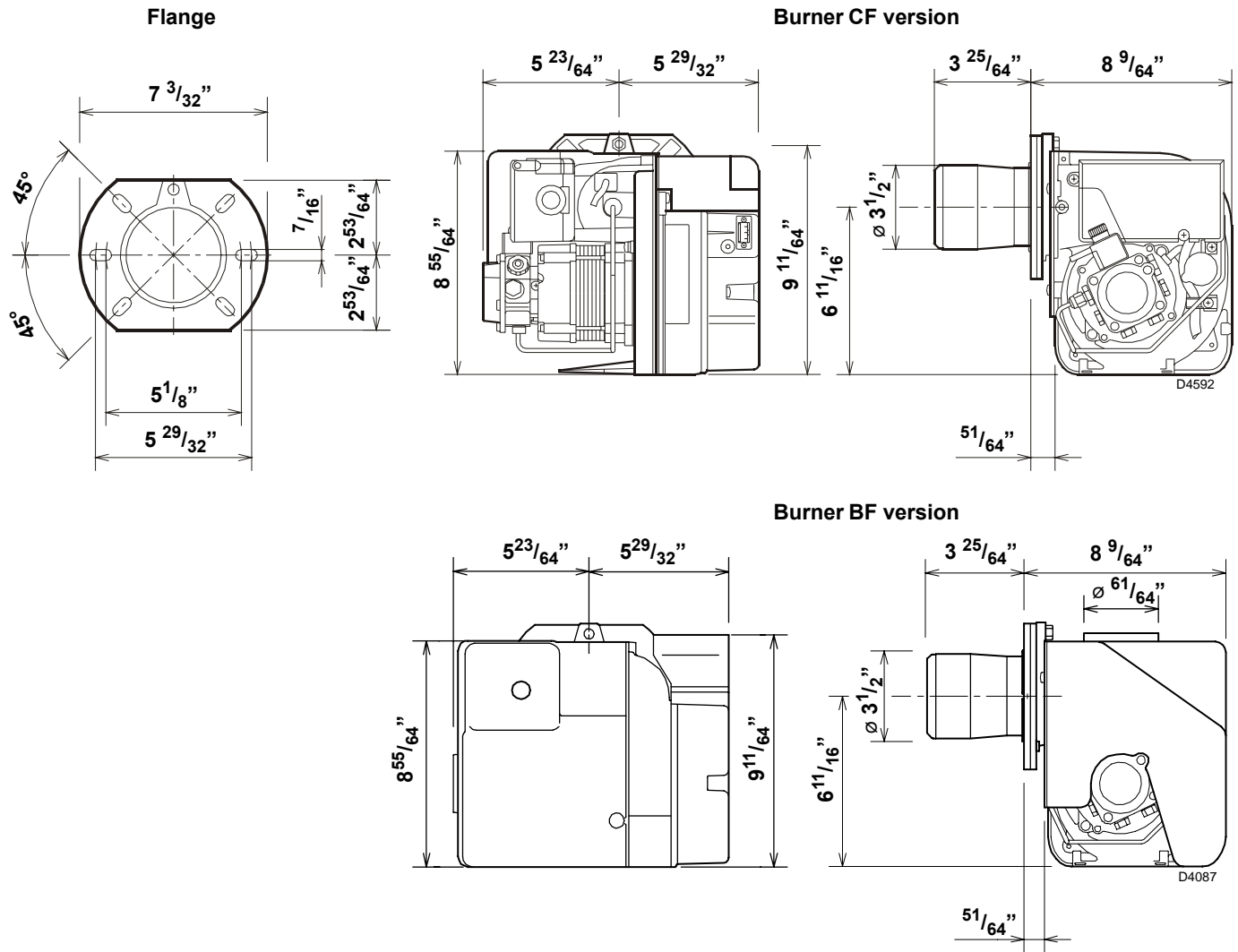

Fig. 3

3.8 Firing rate



The firing rate area values (Fig. 4) have been obtained considering an ambient temperature of 68 °F, and an atmospheric pressure of 30" Hg.

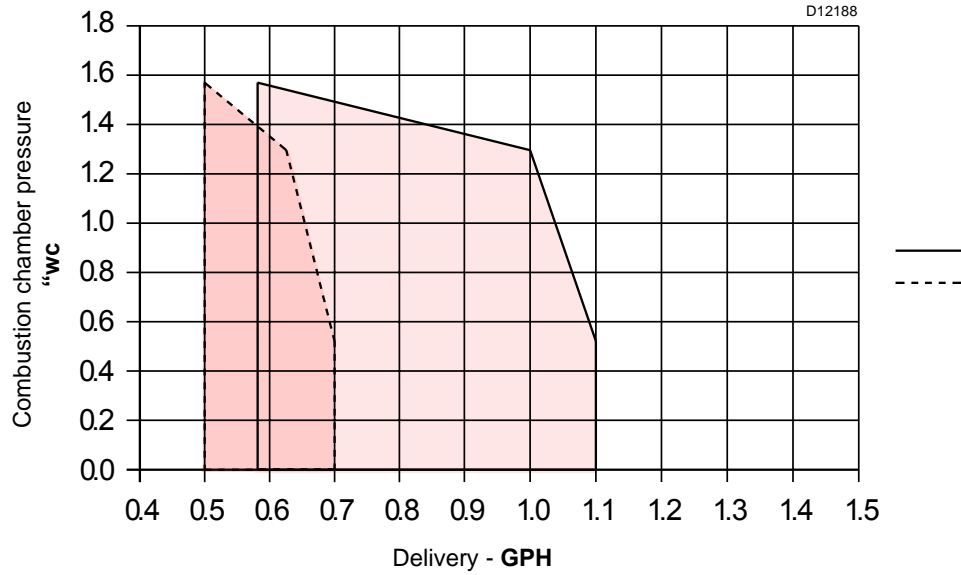

Fig. 4

4.1 Installation precautions

**AIR FOR COMBUSTION**

Do not install burner in room with insufficient air for combustion. Be sure there is an adequate air supply for combustion if the boiler room is enclosed. It may be necessary to create a window to permit sufficient air to enter the boiler room.

The installer must follow local ordinances in this regard.

CANADA It is suggested that the installer follow CSA standard B139.

USA It is suggested that the installer follow NFPA manual #31.

CHIMNEY

Be sure chimney is sufficient to handle the exhaust gases. It is recommended that only the burner be connected to the chimney. Be sure that it is clean and clear of obstructions.

OIL FILTER

An external oil filter is **REQUIRED**, even though there is an internal strainer in the pump.

The filter should be replaced at least once a year, and the filter container should be thoroughly cleaned prior to installing a new filter cartridge.

DRAFT

Follow the instructions furnished with the heating appliance.

The pressure in the combustion area should be kept as close to zero as possible. The burner will operate with a slight draft or pressure in the chamber.

ELECTRICAL CONNECTIONS

CANADA All electrical connections should be done in accordance with the C.E.C. Part 1, and all local codes.

The system should be grounded.

USA All electrical connections should be done in accordance with the National Electrical Code, and all local ordinances. The system should be grounded.

CONTROL BURNER OPERATION

Check out the burner and explain its operation to the homeowner. Be sure to leave the Owner's Instruction sheet with the homeowner.

FIRE EXTINGUISHER

If required by local codes, install an approved fire extinguisher.

ELECTRICAL CONNECTIONS

In most localities, a number 14 wire should be used inside a metal conduit. The system should be grounded.

A service switch should be placed close to the burner on a fireproof wall in an easily accessible location.



The burner settings used in this manual were obtained under laboratory conditions and may vary from those obtained in the actual installation of the burner.

Combustion results must be verified using proper combustion test equipment.

Riello will not be responsible for the improper installation or set-up of the appliance.

4.2 Notes on safety for the installation

After carefully cleaning all around the area where the burner will be installed, and arranging the correct lighting of the environment, proceed with the installation operations.



All the installation, maintenance and disassembly operations must be carried out with the electricity supply disconnected.



The installation of the burner must be carried out by qualified personnel, as indicated in this manual and in accordance with the regulations of authorities having jurisdiction. Reference for the recommended installation practices shall be made to NFPA#31 for USA, CSA Standard B139 (oil burner only) for Canada. Oil-burning equipment shall be connected to flues having sufficient draft at all times, to assure safe and proper operation of the burner.

4.3 Handling

The packaging of the burner includes a wooden platform, so it is possible to move the burner (still packaged) with a transpallet truck or fork lift truck.

With regard to the transport in the obligatory passages, refer to the burner dimensions shown in Fig. 3, page 8.



The handling operations for the burner can be highly dangerous if not carried out with the greatest attention: keep any unauthorised people at a distance; check the integrity and suitability of the available means of handling.

Check also that the area in which you are working is empty and that there is an adequate escape area (i.e. a free, safe area to which you can quickly move if the burner should fall). During the handling, keep the load at not more than 10" from the ground.



After positioning the burner near the installation point, correctly dispose of all residual packaging, separating the various types of material. Before proceeding with the installation operations, carefully clean all around the area where the burner will be installed.

4.4 Preliminary checks

Checking the consignment



After removing all the packaging, check the integrity of the contents. In the event of doubt, do not use the burner; contact the supplier.



The packaging elements (wooden cage or cardboard box, nails, clips, plastic bags, etc.) must not be abandoned as they are potential sources of danger and pollution; they should be collected and disposed of in the appropriate places.



The output of the burner must be within the boiler's firing rate.



A burner label that has been tampered with, removed or is missing, along with anything else that prevents the definite identification of the burner makes any installation or maintenance work difficult.

4.5 Working position



The burner must be installed in conformity with legislation and local standards.

The burner is designed to work only in the positions 1, 2, 3 and 4 (Fig. 5).



Any other position could compromise the correct working of the appliance. Installation 4 is not recommended for safety reasons. Installation 5 is forbidden for safety reasons.

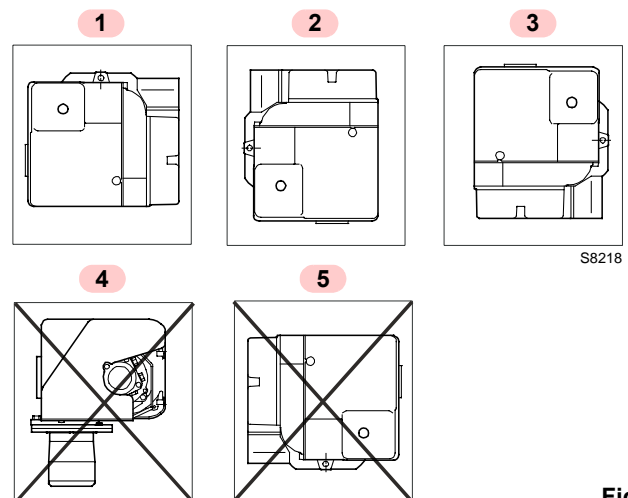

Fig. 5

4.6 Burner assembly

4.6.1 CF - Chimney Vent Application

In case of CF applications, the burner shall not operate without protection **A**(Fig. 6) of the suction inlet.

4.6.2 BF - Direct Vent Application



WARNING

For correct bf application, the burner must be installed on an appropriate BF boiler.

In case of BF applications an optional snorkel and gasket are available replacing **A** with **B**(Fig. 6).

This item can be supplied separately.

The combustion air supply is through a flexible or rigid pipe connected to the air intake.

Consequently, you must comply with the following requirements and instructions:

The combustion air intake tube must be:

- fastened securely to the burner;
- made of a suitable material, with temperature characteristics in the range - 22 °F to 176 °F;
- in compliance with all requirements of applicable regulations in force in the country of destination.
- The intake-tube / burner system must not allow a loss of over 70.67 ft³/h at 0.2"wc: for instance, the above requirements will be met if you use flues for pressure exhaust of flue gases (the condensation kind).
- Make sure the air intake tube's inlet is positioned so that it is not likely to be obstructed by foreign matter and, where necessary, use suitable screens.
- The temperature of the incoming air must not exceed 104 °F;
- The inside diameter of the intake tube must be at least 4 inch.
- The intake tube can be up to 100 ft in length.



WARNING

Length is reduced if there are bends in the intake section.

For instance, using a tube with a smooth inside surface, you must allow for the following losses:

- for each 45° bend, tube length is reduced by 5 ft;
- for each 90° bend, tube length is reduced by 10 ft.



WARNING

Burner installation must comply with one of the installations illustrated in the Fig. 7.

- Under no circumstances should the air's entry in the hose intake area be obstructed.
- The hose must not be blocked in any way or feature a shutting device (valves, membranes etc.).
- Coaxial tubes must not be installed for any reason.

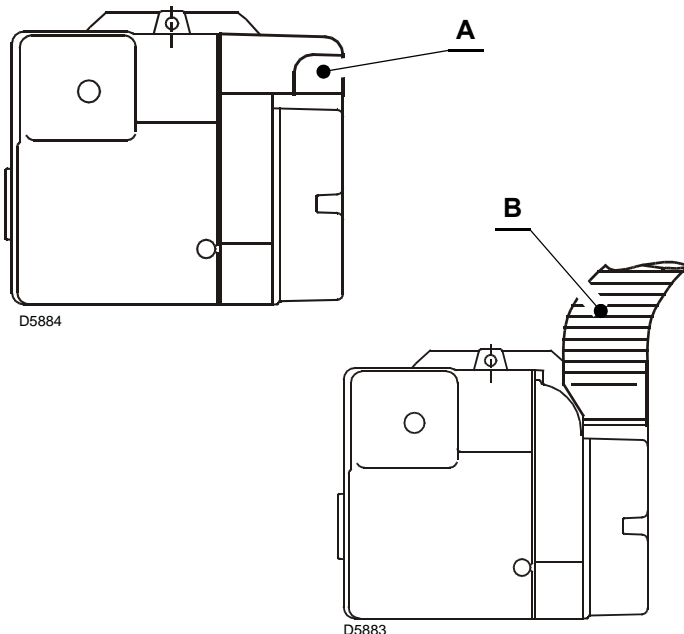

Fig. 6

4.7 A typical layout for RDB burner intake air

- A Use an approved air intake kit.
- B Always keep intake air run to the minimum.
- C Maximum intake air run of 4 (inch) diameter, flexible or rigid type of venting = 100ft.
- D Reduce intake air length by 10' for every 90° elbow used. 5' for every 45° elbow used.
- E It is suggested that air intake venting be insulated with R7 (min.) foil lined insulation a minimum of 10' from air intake source (prevent condensation or corrosion of intake air venting).
- F Used approved type of intake air vacuum breaker and to be installed in the same room and the burner, for the event of intake air source being blocked, this device should be tested to prove that in the event of intake air source is blocked that the vacuum breaker balancer is set correctly and can provide sufficient air for combustion for the burner. If the room that the burner is installed into cannot provide enough air or air quality is a concern, an additional air inlet source will have to be providing to this room.

THIS INTAKE AIR LAYOUT FOR CHIMNEY APPLICATIONS ONLY

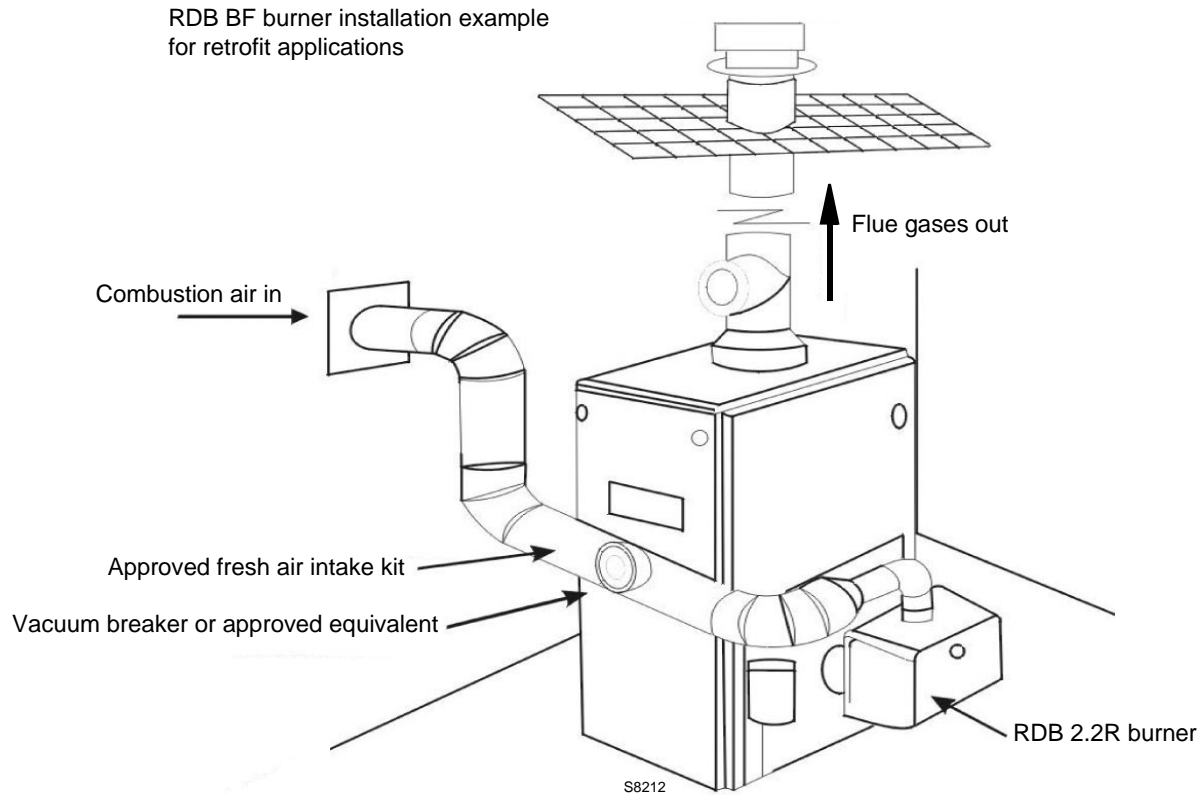
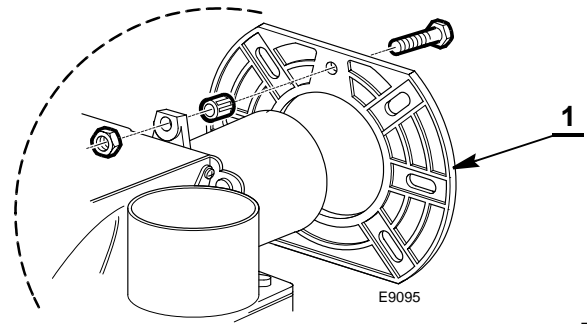
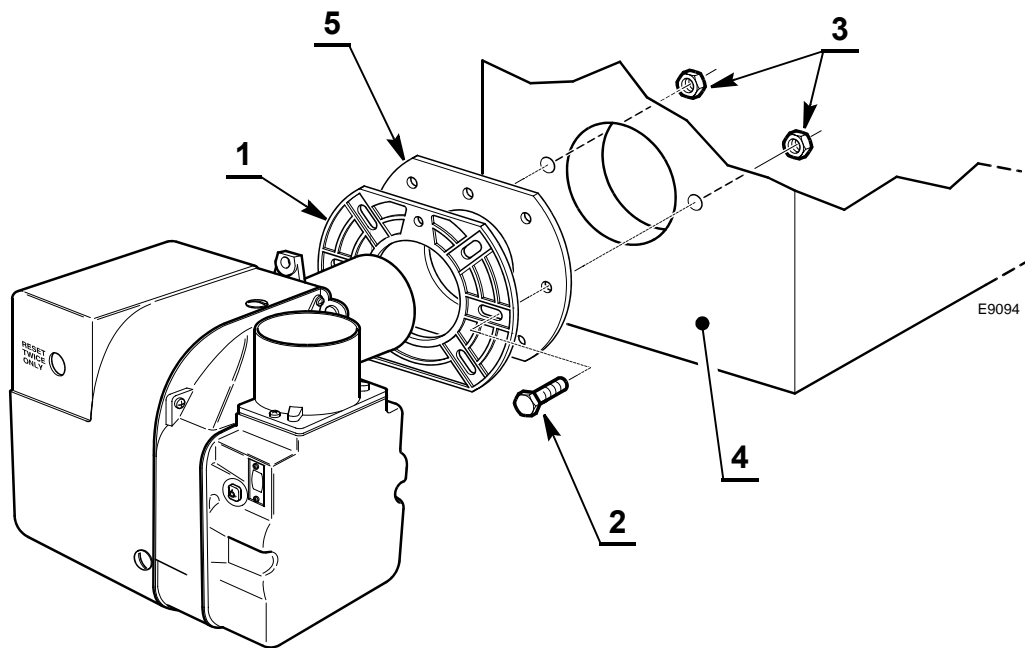

Fig. 7

4.8 Boiler fixing

- Put on the flange 1)(Fig. 8) the screw and two nuts.
- Fix the flange 1)(Fig. 9) to the boiler door 4) using screws 2).
- If necessary, the nuts 3)(Fig. 9) interposing the insulating gas-gasket 5).

**Fig. 8****Fig. 9**

4.9 Hydraulic systems

4.9.1 General warnings

On the market we can find many variants of liquid bio fuels and also blends of mineral and bio-fuels of various origin, including low quality or not standardised products.

For this very important reason, damage to burner hydraulic components can occur, when the fuel is changed.

4.9.2 Oil line connections

This burner is shipped with the oil pump set to operate on a single line system.

To operate on a two-line system the by-pass plug 3)(Fig. 10) must be installed.



- Do not operate a single line system with the by-pass plug installed.
- Operating a single line system with the by-pass plug installed will result in damage to the pump shaft seal.

Pump pressure must be set at time of burner start-up.

A pressure gauge is attached to the pressure port 4)(Fig. 10) for pressure readings. Two pipe connectors 2) are supplied with the burner for connection to either a single or twoline system.

Also supplied are two adaptors 1), two female 1/4" NPT, to adapt oil lines to burner pipe connectors.

All pump port threads are British Parallel Thread design.

Direct connection of NPT threads to the pump will damage the pump body.

Riello manometers and vacuum gauges do not require any adaptors, and can be safely connected to the pump ports.

An NPT (metric) adapter must be used when connecting other gauge models.



The pump requires periodic maintenance carried out by a qualified and authorised technician in conformity with legislation and local standards.

Maintenance is essential for the reliability of the pump, avoiding the excessive consumption of fuel and consequent pollution.



If the pump cover 9) is removed for any reason, be sure the O-ring, is properly seated in the pump cover before re-attaching the pump cover to the pump housing.



The suction plug 10)(Fig. 10) is made of plastic. Once removed, it must not be used again.

In single-pipe installations, the plug in the return line 11)(Fig. 10) must be totally in steel.

In the two pipes systems, before starting the burner make sure that the return pipe-line is not clogged.

An excessive back pressure would cause the damage of the pump seal.



Fuel pipe supply system

- The fuel pipe supply system must be carried out according to the indications supplied in the instruction manual.
- It is advisable to use a pipe with internal diameter of 3/8".
- Check periodically the pipes conditions.
- It is necessary to install a filter on the fuel supply line.



To install the by-pass plug

- Remove the return plug 11) and install the by-pass plug 3) using the 2.5 mm hexagonal key.

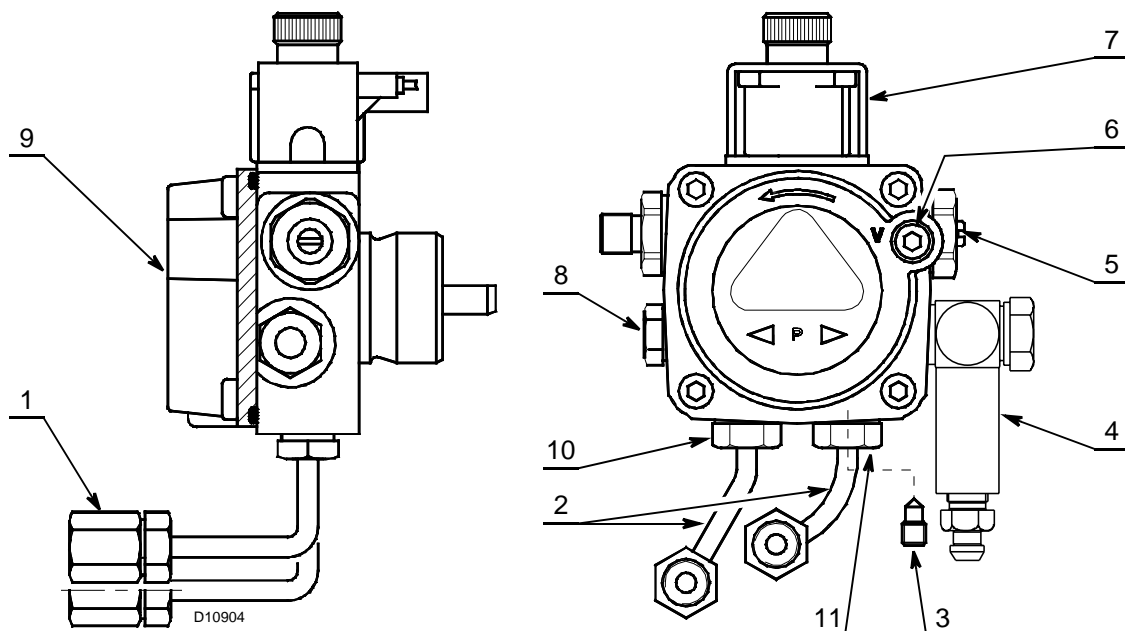

- 1 Adaptors
- 2 Pipe connectors
- 3 By-pass plug
- 4 Pressure port
- 5 Pressure adjuster
- 6 Suction gauge connection

- 7 Valve
- 8 Auxiliary pressure test point
- 9 Pump cover
- 10 Supply port
- 11 Return port

Fig. 10

4.9.3 Priming pump



Before starting the burner, make sure that the tank return line is not clogged.
Obstructions in the line could cause the sealing organ located on the pump shaft to break.

On the system in Fig. 11 it is sufficient to loosen the suction gauge connection 6)(Fig. 10) and wait until oil flows out.

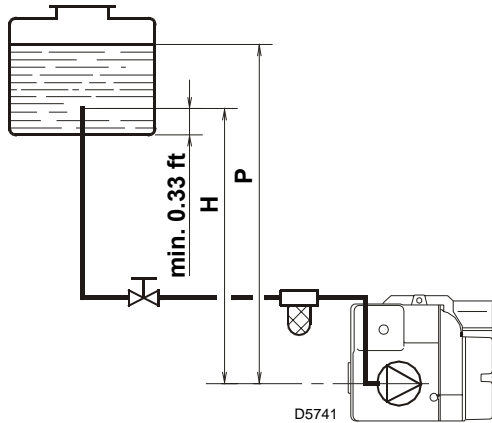

Fig. 11

SINGLE LINE SYSTEM-PIPE LENGTHS		
H ft	L ft	
	3/8"	12/"
1.5	33	65
3.0	65	130
5.0	130	260
6.5	195	325

On the systems in Fig. 12 and Fig. 13 start the burner and wait for the priming. Should lock-out occur prior to the arrival of the fuel, await at least 20 seconds before repeating the operation.

The pump suction should not exceed a maximum of 0,4 bar (30 cm Hg). Beyond this limit gas is released from the oil. Oil pipes must be completely tight.

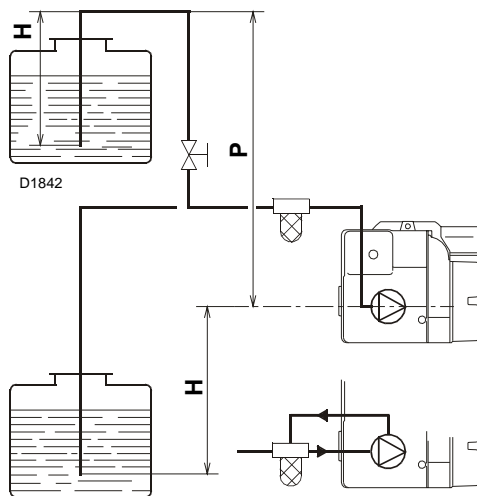

Fig. 12

In the vacuum systems (Fig. 13) the return line should terminate within the oil tank at the same level as the suction line.

In this case a non-return valve is not required. Should however the return line arrive over the fuel level, a non-return valve is required. This solution however is less safe than previous one, due to the possibility of leakage of the valve.

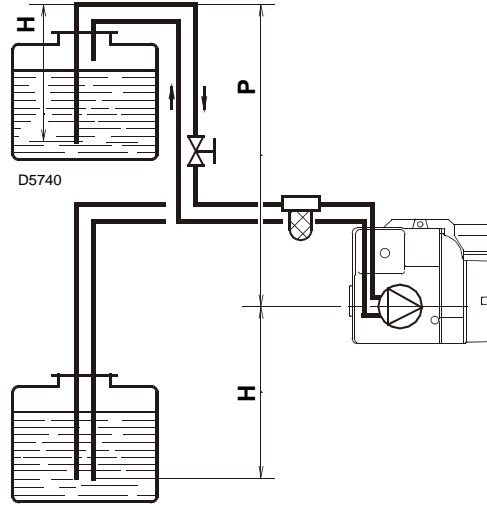

Fig. 13

TWO LINE SYSTEM-PIPE LENGTHS		
H ft	L ft	
	3/8"	12/"
0	115	330
1.64	100	330
3.29	80	330
4.93	65	295
6.58	50	230
9.87	25	100
11.5	20	65

H = difference of level

L = Max. length of the suction line

P = Max. length



- Pipe dope or Teflon tapes are NOT to be used on any direct oil connection to the fuel pump.
- The height 'P' in pipe length charts should not exceed 13 feet (4 m).
- The vacuum should not exceed 11.44 inches of mercury.



An external, appropriately listed and certified oil filter must be placed in the fuel line between the fuel tank and the burner pump.



ALWAYS KEEP THE VALVE FROM THE TANK SHUT OFF IF THE BURNER IS SHUT DOWN FOR AN EXTENDED PERIOD OF TIME.



IT IS IMPORTANT THAT THE FUEL LINE BE COMPLETELY SEALED AND FREE FROM AIR LEAKS OR ANY INTERNAL BLOCKAGES.



WHEN THE BYPASS PLUG IS INSTALLED, A TWO-PIPE SYSTEM MUST BE USED OR FAILURE OF THE PUMP SHAFT WILL OCCUR.

4.10 Electrical wiring

- The electrical wiring must be carried out with the electrical supply disconnected.
- Electrical wiring must be carried out by qualified personnel and in compliance with the regulations currently in force in the country of destination.
- The manufacturer declines all responsibility for modifications or connections different from those shown in the electrical layouts.
- Do not invert the neutral with the phase in the electrical supply line.
Any inversion would cause a lockout due to firing failure.
- The electrical safety of the device is obtained only when it is correctly connected to an efficient earthing system, made according to current standards. It is necessary to check this fundamental safety requirement.
In the event of doubt, have the electrical system checked by qualified personnel.
Do not use the gas tubes as an earthing system for electrical devices.
- The electrical system must be suitable for the maximum input power of the device, as indicated on the label and in the manual, checking in particular that the section of the cables is suitable for the input power of the appliance.
- Do not touch the device with wet or damp body parts and/or in bare feet.
- Do not pull the electric cables.
- Wires of AWG 18 or 16 (0.82 or 1.31 mm²) section and standard rated 221° F. (Unless requested otherwise by local standards and legislation).



Testing:

Check the shut-down of the burner by opening the thermostats and the lock-out by darkening the photoresistance.

4.10.1 Control box

All the installation, maintenance and disassembly operations must be carried out with the electricity supply disconnected.



The installation of the control box must be carried out by qualified personnel, as indicated in this manual and in compliance with the standards and regulations of the laws in force.

To remove the control box (Fig. 14) from the burner proceed as follows:

- loosen the screw 1), open the protection 2) and remove all components;
- remove the coil 3) and loosen the two screws 4);
- move a little the control box and remove the high voltage leads.

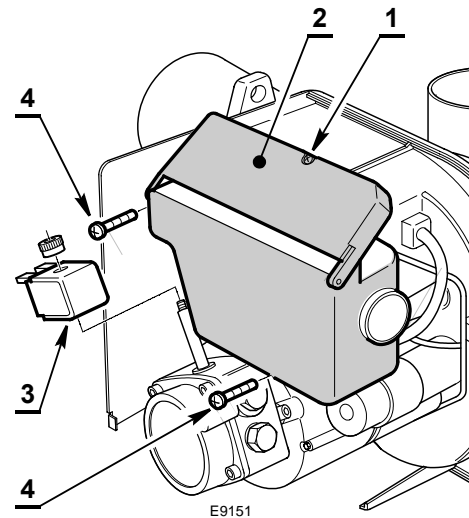
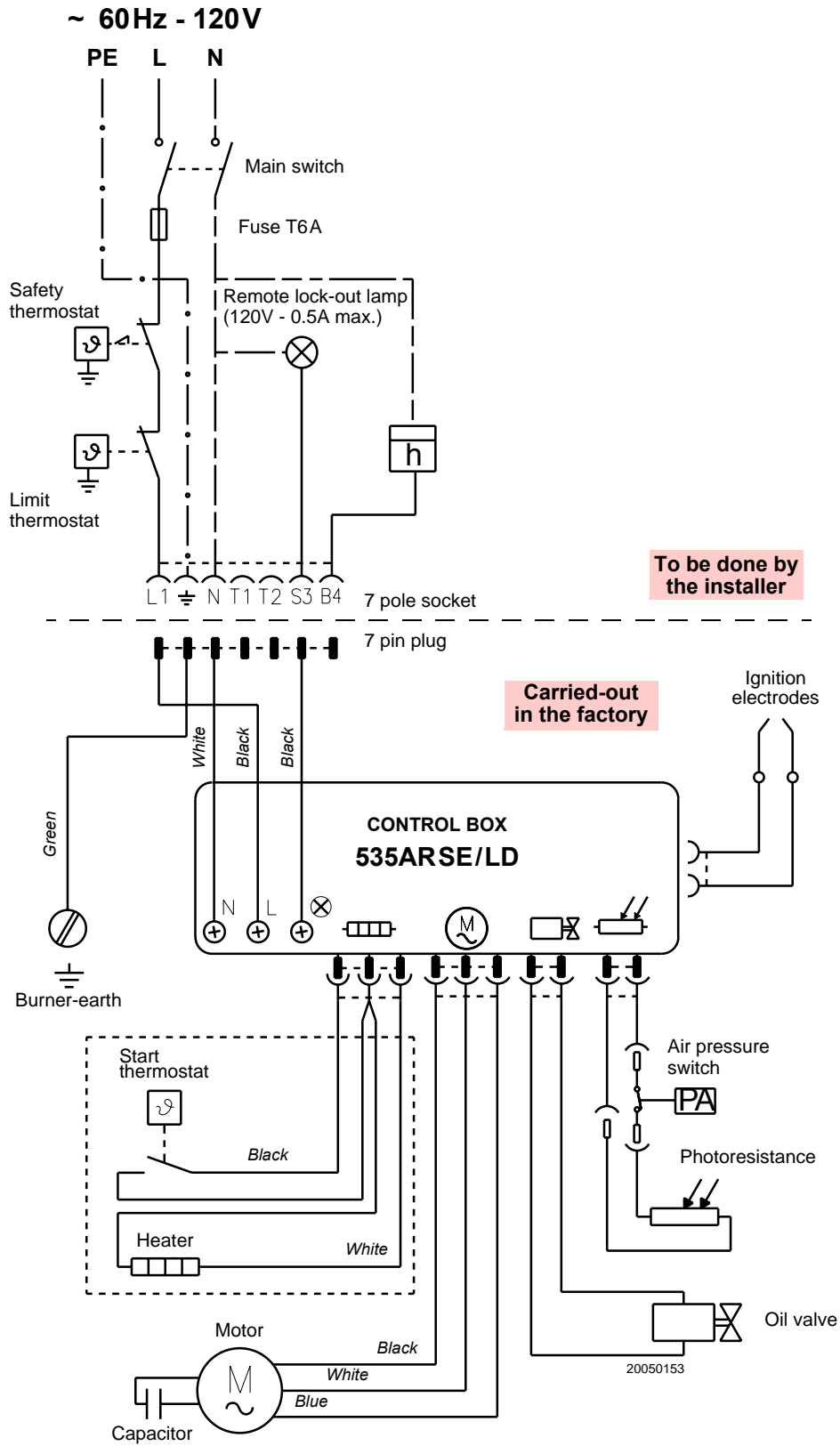

Fig. 14

4.11 Electrical wiring



5 Burner operation

5.1 Combustion adjustment

In conformity with Efficiency Directive UL 296 the application of the burner on the boiler, adjustment and testing must be carried out observing the instruction manual of the boiler, including verification of the CO and CO₂ concentration in the flue gases, their temperatures and the average temperature of the water in the boiler.

To suit the required appliance output, fit the proper nozzle, then adjust the pump pressure, the setting of the combustion head and the air damper opening in accordance with the following table.

Values in the table refer to 12.5% CO₂ and to sea level.



DO NOT USE GASOLINE, CRANKCASE OIL, OR ANY OIL CONTAINING GASOLINE.



DO NOT ATTEMPT TO START THE BURNER WHEN EXCESS OIL HAS ACCUMULATED, WHEN THE FURNACE OR BOILER IS FULL OF VAPOUR, OR WHEN THE COMBUSTION CHAMBER IS VERY HOT.



DO NOT TAMPER WITH THE UNIT OR CONTROLS-CALL YOUR SERVICEMAN.

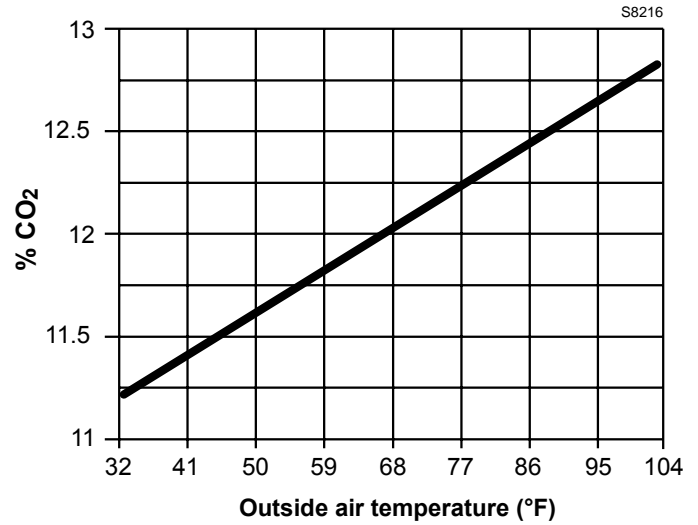

Fig. 15

5.2 Nozzles

The burner complies with the emission requirements of the UL 296 standard. In order to guarantee that emissions do not vary, recommended and/or alternative nozzles specified by the manufacturer in the instruction and warning booklet should be used.



It is advisable to replace nozzles every year during regular maintenance operations.



The use of nozzles other than those specified by the manufacturer and inadequate regular maintenance may result into emission limits non-conforming to the values set forth by the regulations in force, and in extremely serious cases, into potential hazards to people and objects.



The manufacturing Company shall not be liable for any such damage arising from nonobservance of the requirements contained in this manual.

5.2.1 Nozzles recommended

- Delavan
- Danfoss
- Hago
- Monarch

5.3 Pump pressure

The pump is set in factory at the values shown in the Tab. C, page 20.

5.4 Burner adjustment table



The Tab. C indicates initial setting with combustion air at 68 °F.

Model RDB2.2R T1 burner setup chart

Actual firing rate 5% ± US GPH	Nozzle size GPH	Pump pressure PSI	Air damper setting	
			Main (A)	Secondary (B)
0.50	0.40 x 60-80°	175	B	0.00
0.55	0.50 x 60-80°	175	B	2.50
0.60	0.55 x 60-80°	175	B	4.00
0.70	0.60 x 60-80°	175	B	9.50

Model RDB2.2R T3 burner setup chart

Actual firing rate 5% ± US GPH	Nozzle size GPH	Pump pressure PSI	Air damper setting	
			Main (A)	Secondary (B)
0.60	0.55 x 60-80°	175	C	1.25
0.70	0.60 x 60-80°	175	C	3.25
0.75	0.65 x 60-80°	175	C	3.75
0.80	0.70 x 60-80°	175	C	4.75
0.85	0.75 x 60-80°	175	C	5.75
0.90	0.80 x 60-80°	175	C	9.75
1.00	0.85 x 60-80°	175	D	6.00
1.05	0.90 x 60-80°	175	D	6.25
1.10	1.00 x 60-80°	175	D	9.75

FCX22 with Model RDB2.2R T1 burner setup chart

Actual firing rate 5% ± US GPH	Nozzle size GPH	Pump pressure PSI	Air damper setting	
			Main (A)	Secondary (B)
0.62	0.55 x 60° A	185	B	1.50
	0.55 x 60° W	180	B	1.50

FCX30 with Model RDB2.2R T3 burner setup chart

Actual firing rate 5% ± US GPH	Nozzle size GPH	Pump pressure PSI	Air damper setting	
			Main (A)	Secondary (B)
0.82	0.70 x 60° A	185	C	3.25
	0.70 x 60° W	180	C	3.25

Tab. C

- Actual input values given in Tab. C are based on zero (0) chamber pressure, fired in Riello Canada Inc. Test Lab DIN (small) test boiler (chamber length 17", chamber diameter of 11").
Input values calculated using pump pressures listed above in the setup table. Some variations will occur depending on application. This above setup table is used to assist in the initial set-up only.
Proper test equipment must be used to set the burner up properly.
- Please refer to appliance literature or recommendation regarding nozzle size, spray pattern and spray angle.
If no suggestions or literature are given, using above setup table for desired input value set burner to table setting until burner is firing then make suitable adjustments to burner to achieve desirable combustion results.

MODEL RDB2.2R T1, T3 & T5 NOZZLES

Any nozzle manufacturer, size, and angle spray pattern. The appliance in which the burner is installed into determines RDB 2.2R burner nozzle selection.

COMBUSTION CHAMBER

Follow the instructions furnished by the boiler/furnace manufacturer. Size retrofit application according to the appropriate installation codes (e.g. CSA B139 or NFPA #31).

NON-RETROFIT APPLICATIONS

If this burner is packaged with the appliance, it is considered an OEM package; please read all the instructions related to the burner, this information will supersede our installation manual.

5.5 Air damper adjustment

The settings indicated in the Tab. C are purely indicative.

Each installation however, has its own unpredictable working conditions: actual nozzle output, positive or negative pressure in the combustion-chamber, the need of excess air, etc.

All these conditions may require a different air-damper setting.

The air setting is performed by mean of two independent dampers (see Fig. 16 and Fig. 17).

Main air damper (Fig. 17)

To set the positions of the damper, proceed as follows:

- Remove the secondary air damper (B) loosening the screws (1)
- Loosen the screw (2) and rotate the main air damper (A) to the required position.
- Re tighten the screw (2) and put back the secondary air damper (B).

Secondary air damper (Fig. 17)

The purpose of this damper is to perform a fine-tuning of the inlet air. To set the positions of the damper, tuning of this device is possible acting of the screw 3)(Fig. 17).

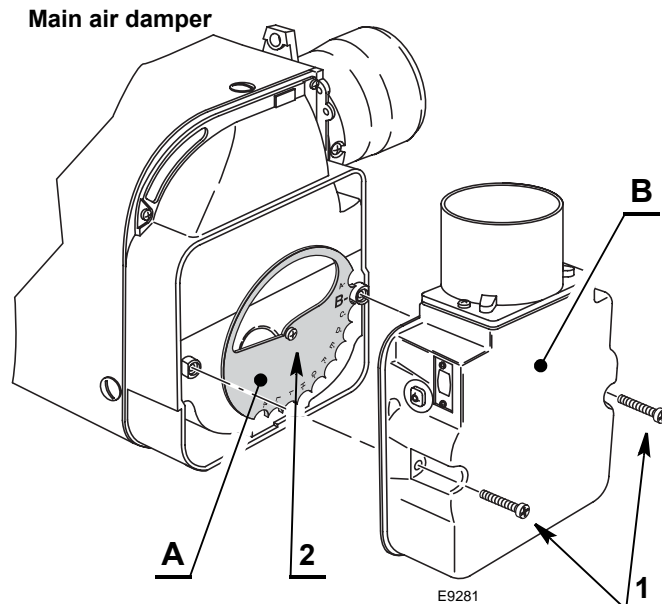

Fig. 16

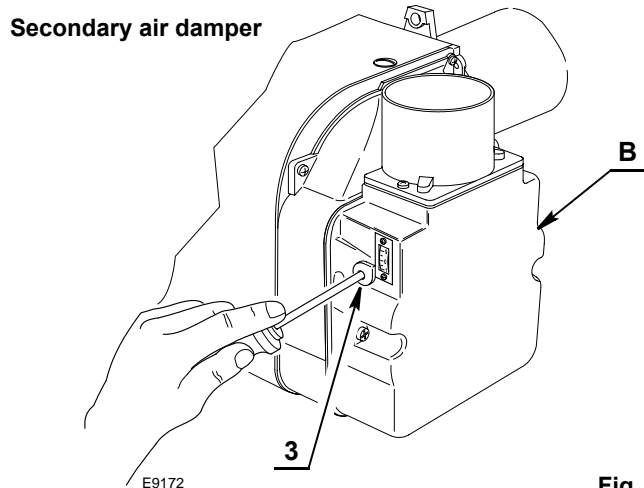

Fig. 17

5.6 Electrodes setting



The installation and disassembly operations must be carried out with the electricity supply disconnected.

To adjust the electrodes proceed as follows:

- loosen the screw 1)(Fig. 18) and move the electrodes ahead;
- fix the screw 1).



Measures must be respected!

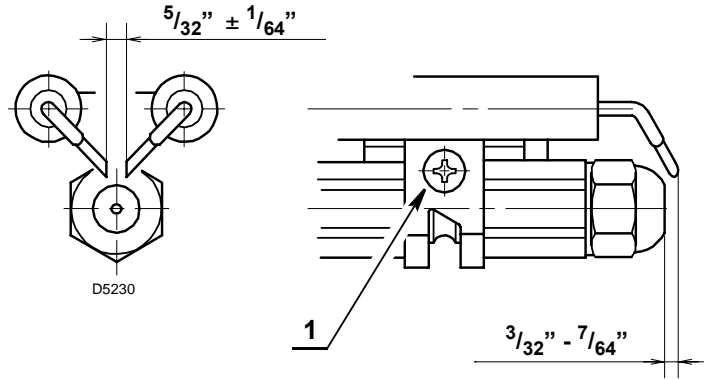

Fig. 18

5.7 Fuel heating

In order to obtain smooth starting and operation across its output range the burner is fitted with an electric resistance, which heats up the light oil in the nozzle line.

The resistance remains energised during working and cuts out when burner shuts-down.

This resistance is energized when the thermostat calls for heat and after a delay of approximately two minutes depending on room temperature, the motor will start.

5.8 Burner start-up cycle

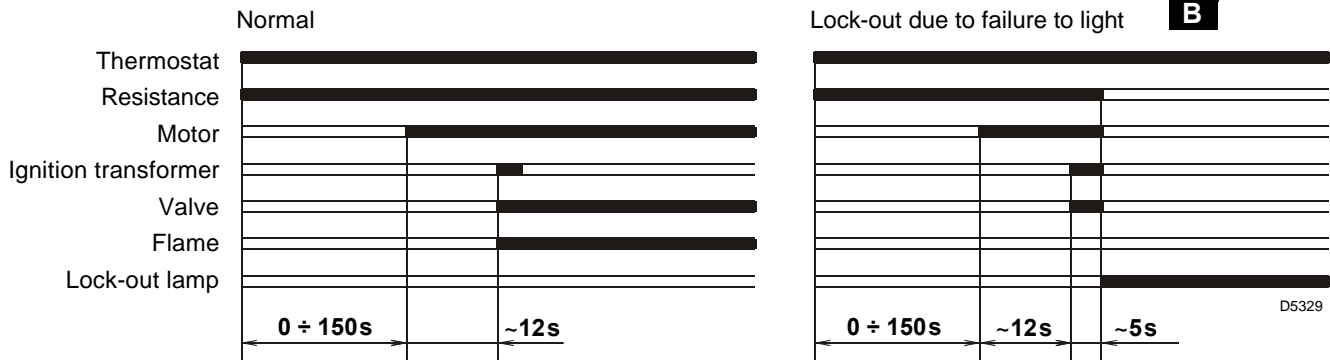

B Lock out is indicated by a lamp on the control box (3, Fig. 1, page 7)

6

Maintenance

6.1 Notes on safety for the maintenance

The periodic maintenance is essential for the good operation, safety, yield and duration of the burner.

It allows you to reduce consumption and polluting emissions and to keep the product in a reliable state over time.



The maintenance interventions and the calibration of the burner must only be carried out by qualified, authorised personnel, in accordance with the contents of this manual and in compliance with the standards and regulations of current laws.

Before carrying out any maintenance, cleaning or checking operations:



Disconnect the electricity supply from the burner by means of the main switch of the system.



Close the fuel interception tap.

6.2 Maintenance programme

6.2.1 Maintenance frequency

The combustion system should be checked **at least once a year** by a representative of the manufacturer or another specialised technician.

6.2.2 Checking and cleaning

Combustion

The optimum calibration of the burner requires an analysis of the flue gases. Significant differences with respect to the previous measurements indicate the points where more care should be exercised during maintenance.

Pump

The delivery pressure must be stable. Unusual noise must not be evident during pump operation. If the pressure is found to be unstable or if the pump runs noisily, the flexible hose must be detached from the line filter and the fuel must be sucked from a tank located near the burner.

This measure permits the cause of the anomaly to be traced to either the suction piping or the pump. If the pump is found to be responsible, check to make sure that the filter is not dirty.

The vacuum meter is installed upstream from the filter and consequently will not indicate whether the filter is clogged or not.

Contrarily, if the problem lies in the suction line, check to make sure that the filter is clean and that air is not entering the piping.

Flexible hoses

Check to make sure that the flexible hoses are still in good condition and that they are not crushed or otherwise deformed. Check periodically the flexible pipes conditions.

Fuel tank

Approximately every 5 years, or whenever necessary, suck any water or other impurities present on the bottom of the tank using a separate pump.

Filters

Check the following filter boxes: on fuel supply line; in the pump; and clean or replace as required.

If rust or other impurities are observed inside the pump, use a separate pump to lift any water and other impurities that may have deposited on the bottom of the tank. Then clean the insides of the pump and the cover sealing surface.

Nozzles

Do not clean the nozzle openings; do not even open them. Replace the nozzles every every year or whenever necessary. Combustion must be checked after the nozzles have been changed.

Combustion head

Check to make sure that all the parts of the combustion head are in good condition, positioned correctly, free of all impurities, and that no deformation has been caused by operation at high temperatures.

Photoresistance

Clean the photoresistance.

Fan

Check to make sure that no dust has accumulated inside the fan or on its blades, as this condition will cause a reduction in the air flow rate and provoke polluting combustion.

Boiler

Clean the boiler as indicated in its accompanying instructions in order to maintain all the original combustion characteristics intact, especially the flue gas temperature and combustion chamber pressure.

Leave the burner working without interruptions for 10 min. and set rightly all the components stated in this manual.

Then carry out a combustion check verifying:

- smoke temperature at the chimney;
- content of CO₂ (%);
- content of CO (ppm);
- smoke value according to opacity smokes index according to Bacharach scale.

Here below you can find some causes and the possible solutions for some problems that could cause a failure to start or a bad working of the burner.

A fault usually makes the lock-out lamp light which is situated inside the reset button of the control box 3)(Fig. 1, page 7).

When lock out lamp lights the burner will attempt to light only after pushing the reset button. After this if the burner functions correctly, the lock-out can be attributed to a temporary fault.

If however the lock out continues the cause must be determined and the solution found.

FAULTS	POSSIBLE CAUSES	SOLUTION
The burner will not start when the limit thermostat closes.	Lack of electrical supply.	Check presence of voltage in the L - N clamps of the control box.
		Check the conditions of the fuses.
		Check that safety thermostat limit is not lock out.
	The photoresistance sees false light.	Eliminate the light.
	Resistance or heating resistance.	Replace them.
Burner runs normally in the prepurge and ignition cycle and locks out after 5 seconds ca.	The connections in the control box are wrongly inserted.	Check and connect completely all the plugs.
	The photoresistance is dirty.	Clean it.
	The photoresistance is defective.	Change it.
	Flame moves away or fails.	Check pressure and output of the fuel.
		Check air output.
Change nozzle.		
Burner starts with an ignition delay.	Check the coil of solenoid valve.	
	The ignition electrodes are wrongly positioned.	Adjust them according to the instructions of this manual.
	Air output is too high.	Set the air output.
	Nozzle dirty or worn.	Replace it.



WARNING

In the event of a burner lockout, more than two consecutive burner reset operations could cause damage to the installation. On the third lockout, contact the Aftersales Service.



DANGER

If further lockouts or burner faults occur, interventions must only be made by qualified, authorised personnel (as indicated in this manual, and in compliance with the laws and regulations currently in force).

8 Spare parts

8.1 Exploded spare parts

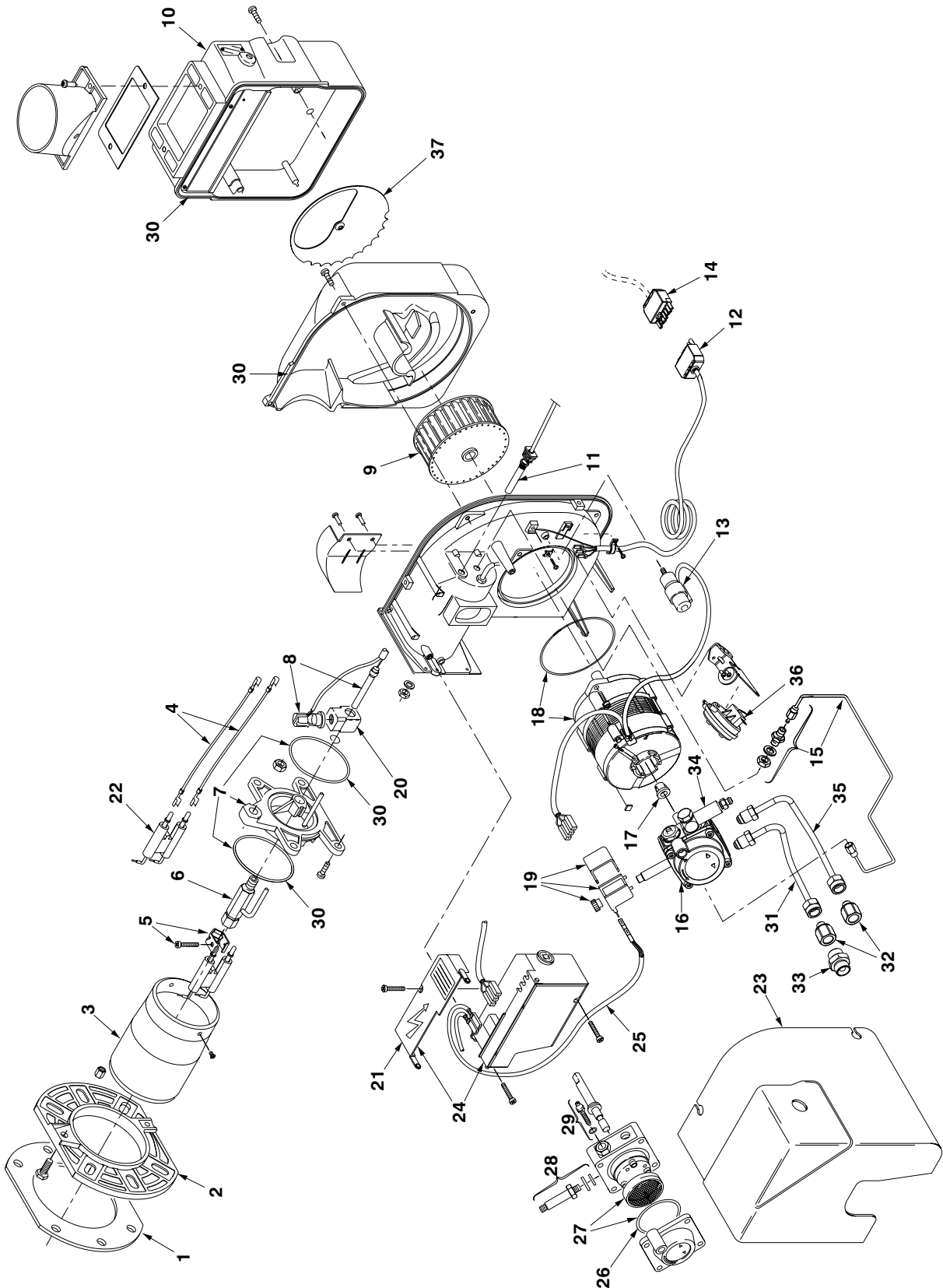

8.2 Spare parts list

N.	CODE	20045452	20045453	DESCRIPTION	*
1	3005787	•	•	GASKET	A
2	3006384	•	•	FLANGE	
3	3002507	•		CUP - SHAPED HEAD	A
3	3002447		•	CUP - SHAPED HEAD	A
4	20029332	•	•	HIGH VOLTAGE LEAD	A
5	3006552	•	•	ELECTRODE BRACKET	
6	3008855	•	•	NOZZLE HOLDER	
7	3008845	•	•	COLLAR	C
8	20029346	•	•	HEALTER ASSEMBLY	B
9	3005788	•	•	FAN	C
10	3008647	•	•	AIR DAMPER ASSEMBLY	C
11	20045943	•	•	P.E. CELL	A
12	20046151	•	•	7 PIN PLUG	
13	3020064	•	•	CAPACITOR 12.5 µF	B
14	3006938	•	•	7 POLE SOCKET	C
15	3008842	•	•	TUBE AND CONNECTOR	
16	3020475	•	•	PUMP	C
17	3000443	•	•	JOINT	A
18	20029357	•	•	MOTOR + CAPACITOR	C
19	3008648	•	•	COIL	B
20	3008856	•	•	CONNECTOR	
21	3008649	•	•	PROTECTION	
22	3020168	•	•	ELECTRODE ASSEMBLY	A
23	20029354	•	•	COVER	
24	20029334	•	•	CONTROL BOX	B
25	20029342	•	•	LEAD COIL	B
26	3007162	•	•	O-RING	B
27	3008653	•	•	FILTER-O-RING	B
28	3007582	•	•	NEEDLE VALVE	
29	3008651	•	•	REGULATOR	A
30	3008878	•	•	KIT SEALS	C
31	3006992	•	•	OIL PIPE	A
32	3005847	•	•	CONNECTOR 3/8" - 1/4"	C
33	3006571	•	•	CONNECTOR 3/8" - 3/8"	C
34	20029329	•	•	BLEEDER	C
35	3006993	•	•	OIL PIPE	
36	20045945	•	•	PRESSURE SWITCH	A
37	20026386	•	•	AIR DAMPER	

*

ADVISED PARTS

A = Spare parts for minimum fittings

A+B = Spare parts for basic safety fittings

A+B+C = Spare parts for extended safety fittings

RIELLO

RIELLO S.p.A.
I-37045 Legnago (VR)
Tel.: +39.0442.630111
[http:// www.riello.it](http://www.riello.it)
[http:// www.rielloburners.com](http://www.rielloburners.com)

RIELLO

35 Pond Park Road
Hingham, Massachusetts,
U.S.A. 02043

RIELLO BURNERS NORTH AMERICA

1-800-4-RIELLO

1-800-474-3556

<http://www.riello-burners.com>

2165 Meadowpine Blvd
Mississauga, Ontario
Canada L5N 6H6